

# Evaluation of Prosim and IPSEpro, Two Heat and Mass Balance Simulation Softwares

**Daniel Häggstahl, Erik Dahlquist**

Mälardalen University, Department of Public Technology  
 Process Optimization and Diagnostic Laboratory  
 P.O. Box 883, SE-721 23 Västerås, Sweden  
 Phone +46 21 15 17 67, Fax +46 21 10 13 70  
 E-mail: daniel.haggstahl@mdh.se , erik.dahlquist@mdh.se

## Abstract

There is a broad range of heat and mass balance commercial software packages on the market. In this article, the advantages and disadvantages of two commercial heat and mass balance software packages for heat and power plant simulation, analysis, optimization and on-line process monitoring are evaluated. The software packages are Prosim from Endat OY in Finland and IPSEpro from SimTech Simulation Technology in Austria. They both have their focus in the power plant area, but they use different methods to calculate the steady-state solution.

A steam cycle has been designed as an application for the software evaluation. The main emphasis of the evaluation is on user-friendliness, the Graphical User Interface (GUI), the component libraries, the calculation time and the calculation accuracy. Another important point is the ability to interact with other software.

The main advantage of Prosim is the broad power plant component library, which contains components for conventional power plants, combined cycles, integrated gasification combined cycles (IGCC), pressurized fluidized bed combustion (PFBC), nuclear power plants etc. A disadvantage of Prosim is the long calculation time, which can be a problem in large-scale calculations. The use of AutoCAD as graphical user interface is not preferable, because AutoCAD is very expensive software.

IPSEpro has a major advantage in its short calculation time, less than 1/6 of the calculation time in Prosim. The model development kit (MDK) in IPSEpro allows the user to change existing or even build new components, which can then be totally integrated into the software.

IPSEpro is a COM-based software, and this increases its potential to interact with other software. The power plant library provided with IPSEpro is small in comparison with the Prosim library. Building the components in MDK can be rather time-consuming. The implicit solver has a drawback: when an error occurs in the calculation, it can be very difficult to find out from the calculation log file where in the process the error has arisen.

## Introduction

Wide range of commercial heat and mass balance simulation, analyzing and optimization software packages are available on the market [1]. These include Aspen Plus [2] and ASCEND [3] for the chemical process industry. Examples of more specialized software are GateCycle [4] and GASCAN+ [5] for gas turbines. This article has its focus on heat and mass balance software packages for heat and power generation.

Two software packages, Prosim from Endat Oy in Finland [6] and IPSEpro from SimTech Simulation Technology in Austria [7], have been tested and evaluated. The two programs have been chosen because they have a similar focus on power plant simulation, analysis, optimization and on-line process monitoring and because they differ greatly in the method used to calculate the steady-state solution. To include other software packages in this evaluation would not lead to any greater differences since they are all more or less variants of these two.

A steam cycle has been designed as an application for the software evaluation. The focus of the evaluation has been on the component libraries supplied with the software packages and on the

user-friendliness of the programs, including the Graphical User Interface (GUI). Other important points are the calculation accuracy, the calculation time and the ability to interact with other software.

## Software

Prosim is a versatile modeling, simulation, analysis and design environment for power processes [6]. The component library has more than 60 components for conventional power plants, combined cycles, IGCC, PFBC, nuclear power plants etc [8]. On request, Endat Oy offers to develop new components. The user has the possibility to develop their own components in Prosim. Prosim provides off-design calculation and exergy optimization of the feed water preheating chain in steam cycles [9]. Simulated annealing [10] is used to find the global optimum. Prosim also has powerful tools for analyzing the turbine expansion curve, the heat exchanger curve and the boiler curve in an Excel-based application [9]. Prosim can also be connected to PulpSim from Arhippainen, Gullichsen & Co for pulp and paper mill simulations [18].

IPSEpro is a highly flexible environment for modeling, simulation, analysis and design of components and processes for energy and chemical engineering [7]. SimTech is currently offering four standard libraries: power plant, gas turbine, refrigeration and desalination [7]. All these libraries include physical properties and the user can also add new physical properties. The power plant library contains components for conventional power plants, cogeneration power plants and combined cycles etc. The gas turbine library contains predefined models of the most common commercial gas turbines on the market. It can be used together with the other libraries for system simulation and analysis. The refrigeration library contains the thermodynamic properties of more than 50 refrigerants and ammonia/water and lithium-bromide/water mixtures for absorption heat pumps. The desalination library contains components for the modeling and optimization of multi-stage flash desalination (MSF) processes [11].

IPSEpro is provided with a model development kit (MDK) for building new components and modifying existing components [12]. MDK consists of a model description language, an icon editor and a compiler. There is also a genetic optimization tool, PSOptimize, available to IPSEpro, where the

user has complete freedom to select variables and define the objective function [10, 14]. Part-load calculations are also available in IPSEpro.

Both Prosim and IPSEpro use MS Windows as operative system. Prosim is developed in FORTRAN with Lisp programming for the GUI in Auto CAD. IPSEpro is developed in a C++ environment.

The process models are built in the same way in both Prosim and IPSEpro. The process building starts with choosing components from the library. The components can then be freely connected by streamlines. After editing sufficient data into components and streamlines, the steady-state solution can be calculated. The result can be viewed both directly in the process scheme and in a text file.

Both Prosim and IPSEpro can export results to Excel for post-processing and graphical presentations. With PSEExcel in IPSEpro, the user can also assign new values to variables and parameters in a fixed process and run a new calculation [14].

Prosim uses AutoCAD as a graphical user interface whereas IPSEpro has its own user interface developed in MS Windows. The graphical design and the way of editing data into components and streamlines are similar in both programs. IPSEpro provides the possibility to change between IFC67 [15] and IAPWS97 [16] formulations of thermodynamic properties of water and steam. In Prosim only the IFC67 formulation is available.

The source code for Prosim is not available to the user in general, only a few fragments are presented in the module reference manual, and the superheater, economiser and air preheater are calculated according to VGB Wärmeatlas. In IPSEpro, the code for the model libraries is open to the user and can be freely changed.

Both software packages can be connected to a distributed control system (DCS) for on-line simulation and process monitoring. IPSEpro is COM-based software that can easily be connected to any other COM-based software.

The solution kernel in IPSEpro is a gradient-based solver utilizing a two stage approach to calculate the steady-state solution. [13, 14]. Most energy and chemical processes are defined by a system of

non linear algebraic equations. The first analyzing phase determines the optimal solution method, by dividing the equations into smaller groups that can be solved successively. The variables in each group are chosen to minimize the group size. The second stage is the numerical solution method; a Newton-based gradient solver that implicitly solves each group successively.

The method of calculating the steady-state solution in Prosim is an iterative Newton-Raphson gradient-based solver. The process components are sequentially calculated using component numbering. To make it easier for the solver to converge, the component numbering should increase in the direction of the main steam flow.

The convergence of the calculation depends strongly on the initial values, which means that the selection of the initial values is a crucial point in building a large-scale system. Both programs have the ability to set the last solution as input values for a new calculation.

## Steam Cycle for Evaluation

The design of the steam cycle has not been optimized in any way. The aim has been to design a process that consists of the components most frequently used in a steam cycle, i.e. boiler, reheater, turbine, alternator, condenser, surface preheater, deaerator (mixing preheater), pump, splitter, pipe and valve.

This steam cycle is shown in Figure 1, it consists of a boiler with reheater, three preheaters, two surface preheaters and one mixing preheater (deaerator). The high-pressure preheater receives steam from the high-pressure turbine. The low-pressure turbine is divided into three stages with extractions to the medium-pressure preheater (deaerator) and the low-pressure preheater. There are two pumps, one condensate pump after the condenser and one feed water pump after the deaerator. The condenser is cooled by sea water.

The water in the system is referred to as “condensate” until it passes the feed water pump. After the feed water pump it is called “feed water”. “Drainage” is the condensate from the steam, extracted from the turbines to preheat the condensate or feed water.

Drainage from the low-pressure preheater is fed back to the condenser, and the drainage from the high-pressure preheater is fed back to the deaerator. The pressure is raised in two steps. The first step is the condensate pump that pumps the condensate to the deaerator through the low-pressure preheater. The second step is the feed water pump that pumps the feed water through the high-pressure preheater to the boiler.

In a commercial steam cycle there are additional components that affect the calculations. In the design shown in Figure 1, the following simplifications have been made:

- No valves to shut off or control components, except for the control valve before the high-pressure turbine.
- No water injection to control the temperature in the superheater or in the reheater.
- No heat exchanger between the condensate pump and the low-pressure preheater to recover heat from leakage steam from the turbine shaft sealings and steam from the condenser vacuum pump.
- No heat recovery from the lubricating oil cooler.
- No steam is used to drive out the air from the deaerator. Typically 0.2 % of the steam flow.
- No losses due to alternator cooling.
- No pressure drop in pipes except for the high-pressure and low-pressure steam pipes.
- No pressure drop in the condenser, deaerator or preheaters.

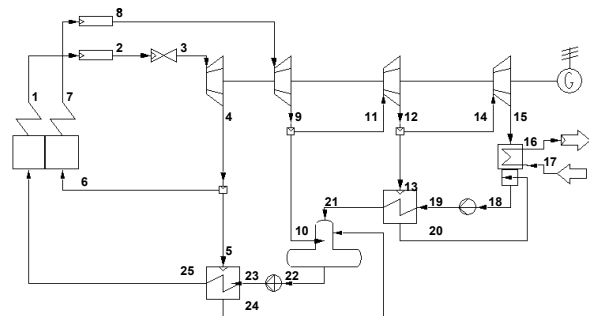

Figure 1. Design of steam cycle

The input data for calculation of the steam cycle are 565 °C, 150.35 bars and 133.919 kg/s of superheated steam at position 1 in Figure 1, and resuperheated steam at 7 is 538 °C. The temperature after the low-pressure turbine at 15 is 19 °C, and the inlet cooling water temperature at 17 is 5 °C and 5 bar. The feed water temperature after the high-pressure preheater at 25 is 245.57 °C and the condensate temperature after the deaerator at 22 is 129.79 °C. This temperature is the mean temperature between positions 25 and 18 [17]. The outlet condensate temperature of the low-pressure preheater at position 21 is 67 °C and is calculated by Equation 1 [17]. This equation is valid for preheater chains without any pumps i.e. with the same flow of in all the preheaters on the feed water side.

$$T_{21} = T_{18} * \sqrt{\frac{T_{22}}{T_{18}}} \quad \text{Temperatures in Kelvin}$$

#### Equation 1. Low pressure preheater exit condensate temperature

The pressure drop in the boiler, including the economizer, evaporator and superheater is 12.4 bars. The pressure drop in the high pressure pipe is 4.65 bars and the heat loss is 5 kJ/kg. The pressure drop in the control valve before the high-pressure turbine is 8 bars. The pressure drop in the reheater is 2.0765 bars and the pipe to the low-pressure turbine causes a pressure drop of 2.0765 bars and a heat loss of 5 kJ/kg. The mechanical efficiency of the turbines is 99 % and the isentropic efficiency is 88 % in the high pressure turbine and 84 % in the first stage of the low-pressure turbine, 83.94 % in the second and 78.95 % in the third. The pump efficiency is 80 % and the alternator electrical efficiency is 98 %.

There are different definitions of the temperature difference on the hot side in the preheater and condenser calculations. The temperature difference on the hot side is often referred to in the literature as the Terminal Temperature Difference, TTD. The definition chosen for this calculation is shown in Figure 2.

In the condenser, the condensate is 2°C sub-cooled and the TTD between the condensation temperature of the steam and the outgoing cooling water is 3°C. In the preheaters, the drainage is 15 °C sub-cooled and the TDD between the saturation temperature of the steam and the outgoing condensate/feed water is 7 °C.

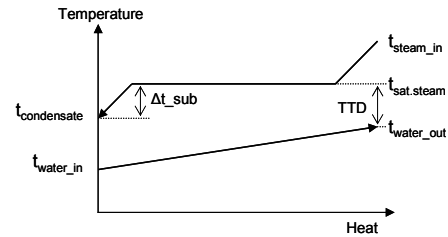

Figure 2. Definitions of sub-cooling and TTD

## Results

The calculations have been performed with both default solver settings and settings to decrease the calculation error. With default settings in Prosim, a minor pressure difference occurred. The calculation results differed by 0.067 bars between the outlet of the feed water pump and the outlet of the high pressure preheater. This difference disappeared when the calculation accuracy was increased.

The only difference in the results from the IPSEpro calculation with default solver settings and settings to decrease the calculation error is in the eighth decimal between the energy flows in and out of the system. With solver settings to decrease the calculation error, the energy flows corresponded completely.

The calculation time is dependent on the solver settings. To make a relevant comparison of the results, the results presented are calculated with default solver settings and with IFC67 formulation of thermodynamic properties. The results of the calculations are shown in Figure 3.

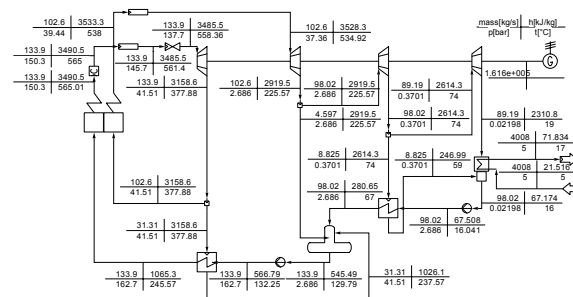

Figure 3. Simulation results in IPSEpro

There are no significant differences between the results obtained with IPSEpro and these obtained with Prosim. Table's 1 and 2 shows the small differences in heat flow in and out of the system. The differences in the results can probably be ascribed to different default solver settings in Prosim and IPSEpro.

**Table 1. Energy flows into the process**

In [MW]	Prosim	IPSE <sub>pro</sub>	Diff
Eco. Evap. SH	324.41	324.78	-0.37
RH	38.47	38.45	0.02
Pump 1	0.03	0.03	0.00
Pump 2	3.02	2.85	0.17
Total	365.93	366.11	-0.19

There is a small difference of 0.15 MW in the Prosim calculations between the energy flows in and out of the system. The calculation was stopped before the algorithm converged, and this means that the difference is probably also a consequence of the solver settings.

**Table 2. Energy flows out from the process**

Out [MW]	Prosim	IPSE <sub>pro</sub>	Diff
Alternator	158.17	158.37	-0.20
Cooling Water	201.57	201.70	-0.13
Pipe 1	0.67	0.67	0
Pipe 2	0.51	0.51	0
Mech. loss turbines	1.63	1.63	0
Generation loss	3.23	3.23	0
Total	365.78	366.11	-0.34

The extremely small pressure difference shown in Table 3 causes a larger difference in the extraction steam flows, as shown in Table 4.

**Table 3. Turbine back pressure**

Position [bar]	Prosim	IPSE <sub>pro</sub>	Diff
4	41.5320	41.5100	0.0220
9	2.6852	2.6860	-0.0008
12	0.3696	0.3701	-0.0005
15	0.02200	0.02198	0.00002

**Table 4. Extraction steam flow to preheaters and condenser**

Position [kg/s]	Prosim	IPSE <sub>pro</sub>	Diff
5	31.26	31.31	-0.05
10	4.67	4.60	0.07
13	8.86	8.82	0.03
15	89.13	89.19	-0.06

The main difference between the programs is in the calculation time. With a 2.4 MHz CPU and 1 Gb RAM and the hardware lock mounted on the computer, the calculation time in Prosim was 5.8 seconds and in IPSEpro it was much less than one second. In IPSEpro, the calculation is performed in less than 1/6 of the time used by Prosim.

In the result obtained, the differences between Prosim and IPSEpro are extremely small. The largest difference was 0.37 MW between the heat flow calculations into the system, as shown in Figure 1, which corresponds to an a difference of 0.11 %. In simulation, design, analysis, optimization and on-line process monitoring, errors of that order of magnitude do not endanger the accuracy of the results. There are usually much greater uncertainties in the input data.

## Discussion

The simulation time can be a crucial point for the user. For large-scale systems, simulation times up to 30 seconds or even longer are not uncommon in Prosim and that can be quite annoying for the user. The simulation time in IPSEpro is not much longer than one second, even for large-scale systems, and this makes IPSEpro especially suitable for these applications.

The closed source code in Prosim may not be a problem for the experienced user, but for beginners and for educational purpose the open source code in IPSEpro is preferable. The user can then easily access the equations for the components. Of course the user of Prosim can look in the manual or in VGB Wärmetlas for the equation, but that is more complicated.

The Excel-based analysis tools for the turbine expansion curve, the heat exchanger curve and the boiler curve in Prosim are very powerful. Unfortunately IPSEpro is not provided with any analysis tool for turbine expansion curves etc. and it can be time-consuming to develop such tool in Excel.

The two software packages have different approaches. IPSEpro is a highly flexible simulation and modelling platform where it is possible to simulate everything that can be represented by a network of discrete components and their connections. Prosim is a simulation platform with a focus on the power plant sector.

## Conclusions

Both Prosim and IPSEpro are very user-friendly programs. It is easy to build a process model by selecting modules from the library and adding sufficient data into components and streamlines. The GUI is also similar in both programs. There are some small differences in the component icons.

The primary advantage of using Prosim is the broad power plant component library with components for conventional power plants, combined cycles, IGCC, PFBC, nuclear power plants etc. The components are adapted to physical parts in power plants. For example, the reheater is included in the boiler component. An advantage of the sequential solver in Prosim is that when the user tries to calculate a non-working process, the sequential solution method stops the calculation at the point where the problem occurs.

A disadvantage of Prosim is the long calculation time that can be quite annoying for the user. Another disadvantage is that the software AutoCAD, used by the program as GUI, is very expensive. One confusing issue with Prosim is that it is possible to edit more input data to the process than are necessary for the calculation, and the solver itself decides which data shall be used. In general, efficiencies, TTD and other component data have a higher priority than other process data.

The main advantage of IPSEpro is that the user is free to develop new or to change existing components in MDK and to add new physical properties. The new components are then totally integrated into the software. The fast calculation time is a great advantage for IPSEpro. Another advantage is the open source code for the component libraries, which gives the user the possibility to easily understand how the process is calculated.

A disadvantage of IPSEpro is that it is not provided with a large component library and it can be quite time-consuming to develop the components in MDK. The implicit solver has one drawback: when an error occurs in the calculation it can be very difficult to identify from the calculation log file where in the process the error has occurred.

## Future Work

A more detailed boiler model in the steam cycle and a comparison of part-load simulations would give a more comprehensive evaluation between Prosim and IPSEpro.

## Acknowledgements

First of all, we should like to thank the founder of Endat Oy, Prof. Carl-Johan Fogelholm, and the founder of SimTech Simulation Technology, Mr. Erhard W. Perz, for supporting us with valuable information about their software. We also should like to thank PhD Stud. Christer Karlsson, Mälardalen University, Dept. of Public Technology for supporting us with useful information about Prosim.

## References

1. Assadi M, "Utveckling av effektivare värmebalansprogram för fullast- och dellastberäkningar av kraftsystem", Licentiate Thesis, Lund Inst. Of Technology, Dept. of Heat and Power Eng. ISSN 0282-1990, 1997
2. Aspen Plus, [www.aspentech.com](http://www.aspentech.com), 2003
3. ASCEND, [www-2.cs.cmu.edu/~ascend](http://www-2.cs.cmu.edu/~ascend), 2003
4. GateCycle, [www.gepower.com](http://www.gepower.com), 2003
5. GASCAN+, [www.thermoflow.com](http://www.thermoflow.com), 2003
6. Prosim, [www.endat.fi](http://www.endat.fi), 2003
7. IPSEpro, [www.simtechnology.com](http://www.simtechnology.com), 2003
8. Prosim, "Module reference manual", August 2002
9. Prosim, "Interface guide", version 4.2, 2002
10. Pham et al., "Intelligent optimisation techniques", Springer, 2000
11. Arshad, et al, "Desalination processes and multistage flash distillation practice", Elsevier, ISBN 0-444-42563-2, 1986
12. IPSEpro, "Manual, Model development kit", version 4.0.001, 2003
13. Fletcher, Roger, "Practical Methods of Optimization", Wiley, 1987
14. IPSEpro, "Manual, PSE", version 4.4.001, 2003
15. Schmidt, E, "Properties of Water and Steam in SI-units", Springer, 1969
16. Wagner, W, "Properties of Water and Steam", Springer, 1998
17. Traupel, W, "Thermische Turbomaschinen I", 3 Auflage, Springer, 1977
18. Pulpsim, [www.agco.fi](http://www.agco.fi), 2003